



**3^ο Διεθνές Συνέδριο
Αρχαίας Ελληνικής
και Βυζαντινής Τεχνολογίας**

19-21 Νοεμβρίου 2024
ΜΕΓΑΡΟΝ ΜΟΥΣΙΚΗΣ ΑΘΗΝΩΝ

**3rd International Conference
Ancient Greek
and Byzantine Technology**

19-21 November 2024
MEGARON THE ATHENS CONCERT HALL

ΟΡΓΑΝΩΣΗ



ΕΤΑΙΡΕΙΑΣ ΔΙΕΡΕΥΝΗΣΗΣ
ΤΗΣ ΑΡΧΑΙΟΕΛΛΗΝΙΚΗΣ ΚΑΙ
ΒΥΖΑΝΤΙΝΗΣ ΤΕΧΝΟΛΟΓΙΑΣ



Το Διοικητικό Συμβούλιο της Εταιρείας Διερεύνησης της Αρχαιοελληνικής και Βυζαντινής Τεχνολογίας (ΕΔΑΒΥΤ) ανέλαβε την ανάρτηση στην ιστοσελίδα της (www.edabyt.gr), σε ψηφιακή μορφή, των εργασιών του 3^{ου} Διεθνούς Συνεδρίου Αρχαιοελληνικής και Βυζαντινής Τεχνολογίας (Αθήνα 19-21 Νοεμβρίου 2024).

Οι εργασίες είχαν γίνει αντικείμενο κρίσεων και σχολιασμού από την Επιστημονική Επιτροπή. Επιπλέον, έγιναν κι άλλες παρατηρήσεις και σχόλια κατά την συζήτηση που ακολούθησε μετά την προφορική τους παρουσίαση στο Συνέδριο.

Οι εργασίες αναρτώνται όπως κατατέθηκαν από τους συγγραφείς μετά την ολοκλήρωση του Συνεδρίου. Οι συγγραφείς φέρουν την ευθύνη του περιεχομένου της εργασίας τους, τόσο ως προς τις απόψεις τους όσο και ως προς την ακρίβεια και την ορθότητα των στοιχείων που παραθέτουν.

The Board of Directors of the Association for Research on Ancient Greek and Byzantine Technology (EDABYΤ) undertook the posting on its website (www.edabyt.gr) of the papers presented at the 3rd International Conference on Ancient Greek and Byzantine Technology (Athens, November 19-21, 2024).

The papers had been subject to reviews and comments by the Scientific Committee. Additionally, further observations and comments were made during the discussion that followed their oral presentation at the Conference.

The papers are posted as submitted by the authors after the conclusion of the Conference. The authors are responsible for the content of their work, both in terms of their views and the accuracy and correctness of the data they present.



NERO'S *CENATIO ROTUNDA* ON THE PALATINE HILL. AN EXAMPLE OF HELLENISTIC ENGINEERING

Edoardo Gautier di Confiengo,
Independent Engineer, edoardo.gautier@gmail.com

Abstract. A recent unexpected archaeological discovery in Rome on the Palatine hill has brought to light a mighty building structure from the Neronian period. The walls built in the NE corner of the Palatine to form the terrace of Domitian have hidden this complex until the present days.

It is a very well-preserved masonry structure that consists of a 21 m high central pillar with a diameter of four metres from the top of which eight arches branch depart. The latter depart to a cylindrical ring with an inner diameter of twelve metres and an outer diameter of sixteen metres. An annular ring floor on the lower level is supported by another eight arches. A spiral staircase from the ground floor ascends to the intermediate floor. A recess in the annular body in the volume between two arches at a height of 6 m, between the two levels, shows clear traces of demolition with a pickaxe and parts of iron beams still anchored within the masonry.

The building in ancient times was cut off from other structures stripped of all valuable components. What remains has allowed to attribute the building to Nero's *cenatio rotunda*, the courtly hall that rotated day and night (Suet. *Nero* 31.1), of the palace built by the *magistri machinatores* Severus and Celere (Tac. *Ann.* 15,42).

The paper attempts to reconstruct the structure and operation of the *cenatio rotunda* and proposes a wooden platform rotating by means of a water powered mechanism, *hydraleta*, connected with a gear system.

Two hypotheses of machine operation are considered. The first proposes a number of wheels placed between two wooden platforms, one fixed and locked on the masonry floor and the other forming the *cenatio*. In this case, the system is considered almost a rotating turntable.

A second hypothesis considers the platform of the *cenatio* as a raft floating above a carpentry tank containing water, resting on the masonry.

Theoretically both hypotheses could work, but, considering the involved forces, the *hydraleta* can rotate the *cenatio* only as a raft

Key words: Water-powered mechanism, gear system, Nero, Palatine, *Domus Aurea*, *cenatio rotunda*.

1 Introduction

Excavations by the Soprintendenza Archeologica di Roma and the École Française de Rome on the Palatine Hill between the years 2009 and 2014¹ have brought to light an imposing masonry structure approximately 21 m high hidden by the mighty walls built between the 70s and 80s AD to create a large artificial terrace, now called Vigna Barberini, reshaping the north-east corner of the hill². The burying of the large soil volume generated in this enterprise sealed for 20 centuries what had previously existed. The structures are made of bricks and construction techniques that have allowed archaeologists to date the building to the Neronian period (AD 64-68) and attribute it to a pavilion of Nero's imperial palace on the Palatine, previously unknown.

The building, largely amputated by imposing substructures of the Flavian period, consists of three concentric, circular elements, as shown in the plan (Fig. 1). Structure A has only been identified in two short sections that characterise its cylindrical inner surface with a diameter of 21.90 m. More defined is the internal structure that consists of a cylindrical ring (B) with an external diameter of approximately 16 m and a thickness of 2.07 m, connected by a double series of eight round arches to a central core, the pillar C with a diameter of approximately 4 m. A spiral staircase within the C pillar connects the ground floor to the annular corridor, without continuing to the upper floor. From the foundation to the top floor, the structure is 20,80 m high (Fig. 2). The second series of arches, similar to the previous ones, forms an intermediate floor with an annular corridor 5.93 m below the top floor (Fig. 2). The entire building consists in carefully constructed masonry³, similar in materials to the Nero's *Domus Aurea* on the Oppian Hill.

The building turns out to be the lower portion of a pavilion of the emperor's official palace, the Palatine *Domus Aurea* dedicated to Nero's official ceremonies⁴. This identifies another part of a large complex that led from the atrium (*vestibulum*), dominated by the Colosseum, to the pavilion on Oppian Hill, the lake and the gardens. The palace on Oppian Hill turns out, with this finding, to be the private part of the residence⁵. The design of the monumental complex, conceived according to the Alexandrian examples of the Ptolemy palaces⁶, was entrusted to the two architects Severus and Celere (Tac. *ann.* 15, 42). Suetonius adds that Nero's palace contained the "*praecipua cenationum rotunda, quae perpetuo diebus ac noctibus vice mundi circumageretur*" (Suet. *Nero* 31, 1)⁷, a statement that invites us to look for elements of a possible machine that rotated the *cenatio*. Fragments of extirpated iron beams and their imprints in a specific sector indicate part of the probable space intended for

* Thanks to the Association for the Research of the Ancient Greek and Byzantine Technology, organizer of the Athens conference, which enabled a fruitful dialogue between the two disciplines Archaeology and Technology. Thanks to Paul Kessener for the suggestions and corrections that have improved the paper.

¹ Villedieu 2010, 2016, 2021.

² On the complex events of the N-E corner of the Palatine, Coarelli 2012, 497 – 538, Villedieu 2007, 379 - 389 and 2021, 9 – 23, Häuber 2024.

³ Fedeli 2021, 259, s.

⁴ Moormann 2020, 19 – 23.

⁵ Moormann 2020, 21, Panella 2013, 99 – 103; 110. Coarelli 2021, 423 – 426.

⁶ Voisin 1987.

⁷ The chief banqueting room was circular, and revolved perpetually, night and day, in imitation of the motion of the celestial bodies (Suet. *Nero* 31.1, trans. A. Thomson 1889).

the machine. Concrete evidence of important mechanical structures were removed already in ancient times.

A recent publication attributed this structure to the lower part of a viewing tower in Nero's Palatine gardens⁸, another one to that of a lighthouse in imitation of the Alexandria's Pharos⁹, but both proposals are without justifications and comparisons related to archaeological structures.

The structure found is enclosed within massive concrete castings from the Flavian period, only future excavations in the space around it may identify the buildings that provided access to the upper and intermediate floors.

2 The 2009-2016 excavations on the Palatine

2.1 The rediscovered structures

The archaeological excavation of the NE end side of the Flavian terrace of the Palatine was carried out within the area delimited by the dotted lines of the plan presented in Fig. 1. The excavation identified the Neronian part of the structure, highlighted in solid colour, bordered by massive concrete casts that in the Flavian period incorporated the pre-existing structures, and are an important part of supporting ramparts of the Flavian terrace. The symmetries found in the portion of the Neronian building brought to light allowed archaeologists to reconstruct the entire structure by completing the cylindrically shaped parts shown in light colour (Fig. 1, 2).

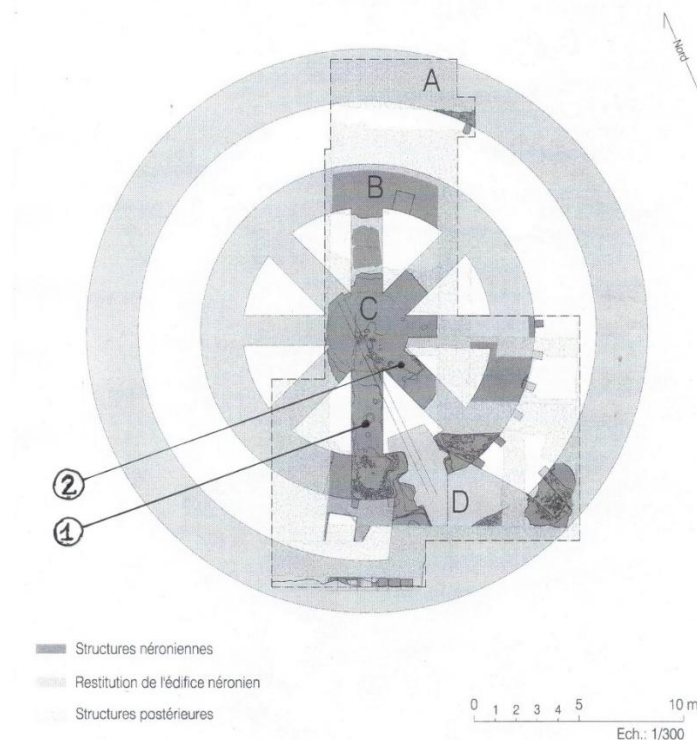

Figure 1. Plan of the upper surface of the Neronian building (drawing N. André, AMU-CNRS, IRAA, modified).

⁸ Bruno 2017, 239.

⁹ Jolivet 2023a, 314, Jolivet 2023b.

The excavations have brought to light on the part A only what is shown in bold in Figure 1, which allows us to hypothesise the presence of an inner cylindrical surface measuring 21.90 m in diameter¹⁰, but the drawing of this circumference is purely indicative.

The cylindrical ring B, well-defined in shape and dimensions in the plan and section, lies at an altitude of 43,7 m asl¹¹. It is formed by a ring with an external diameter of 16 m and an internal diameter of 12 m, which is connected to the central pillar, having a diameter of 3,85 m, by eight full-centre arches supporting the top floor, and, beneath these, by another eight arches supporting an intermediate floor 6 m below. A spiral staircase built inside the masonry of pillar C descends from the intermediate floor descends to ground level at 22,90 m asl¹².

In the structure, the space marked with D between ring B and A in the plan is highlighted (Fig. 1); the same space in the section (Fig.2) is located between the top floor and the intermediate floor. On the vertical surfaces there are evident traces of demolition carried out with pickaxe blows, a few pieces of iron and imprints of metal beams were left embedded in the masonry. On these elements, four horizontal bars, parallel to each other, can be reconstructed. They are approximately 3.35 m long with a 38 x 26 mm cross-section, that go through the D space at a distance of 1.4 m in the same vertical plane¹³ (fig. 3). Other imprints of bars with pieces of iron are evident on the same vertical walls facing each other, while an inverted U-shaped iron bracket of about 30 cm high still remains. Imprints in the mortar of two other similar brackets can be found elsewhere in the D space. This appears to be part of a reticular structure that at present can be reconstructed only in the vertical plane.

Some research people came up with the hypothesis that this compartment contained part of the machine that moved the cenatio.

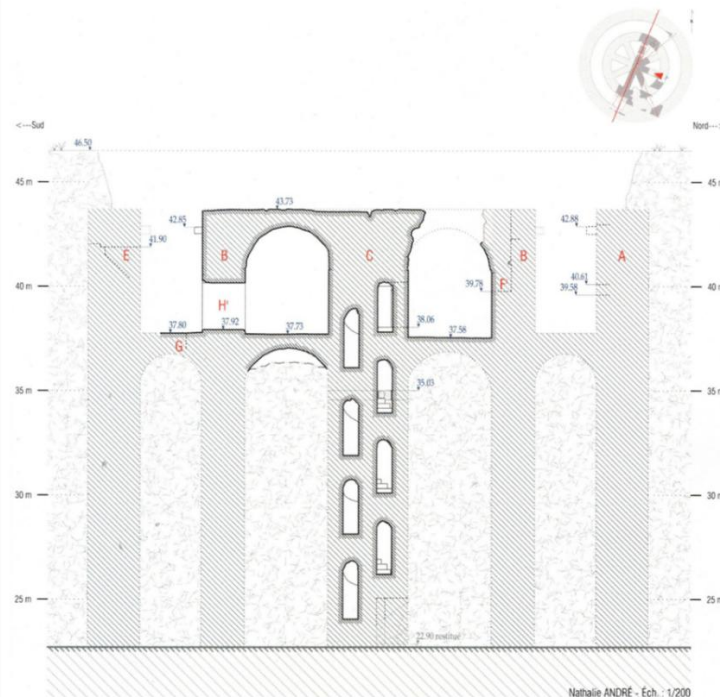

Figure 2. North-South section of the Neronian structure (draw N. André, Villedieu 2021, 201, fig. 144).

¹⁰ Villedieu 2021, 208-210, 352-353, Tav IV.

¹¹ Villedieu 2021, 201, fig.144.

¹² Villedieu 2021, 219-228, fig. 173.

¹³ Villedieu 2021, 241, fig. 223.

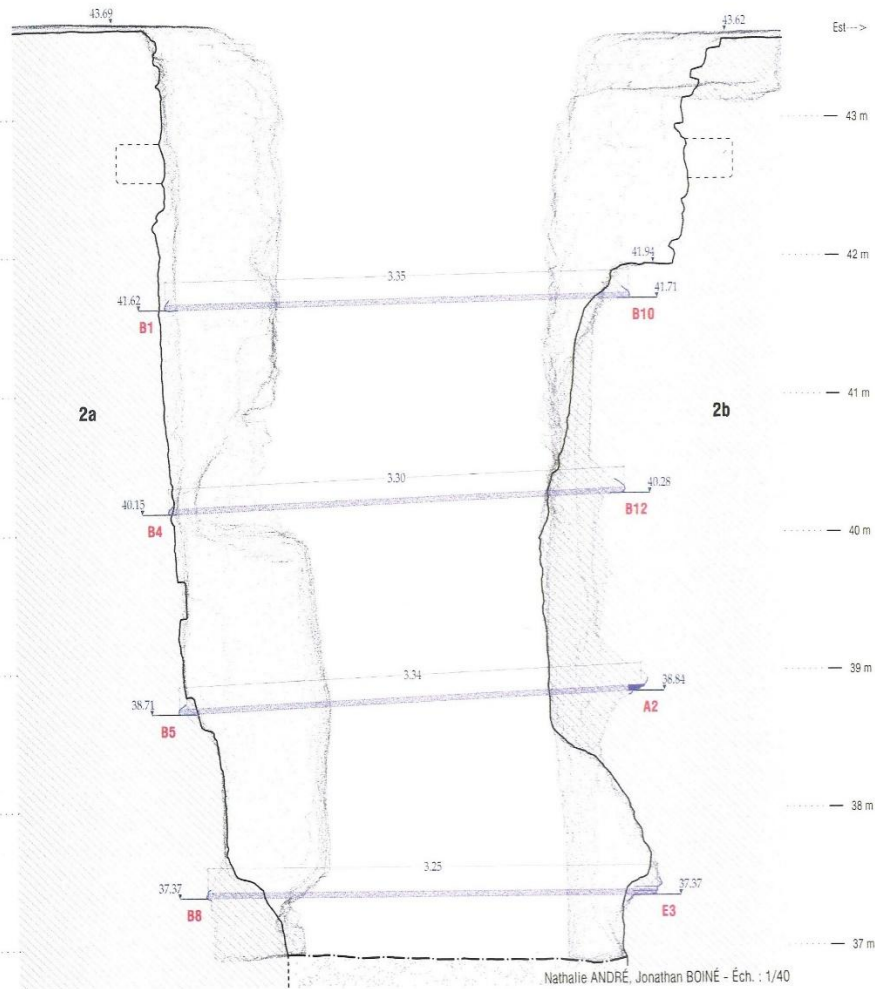

Figure 3. Space D vertical section with reconstruction of the four iron bars (Villedieu 2021, p. 247, fig. 223).

1.2. Functional analysis of the structures

The demolitions that took place in the Flavian period do not allow for the identification of the different parts of the building. Therefore, only the items considered useful for the purposes of a hypothetical reconstruction of a machine are discussed in the following.

The surface of the upper floor (basement) still retains, for the most part, the mortar of the Neronian period¹⁴, which in the centre presents an irregularly conical shaped hole with a base of approximately 16 cm in diameter, and 26 cm deep. There are also six hollows of hemispherical shape with a diameter of 26-30 cm, created by chiselling the existing surface¹⁵. The position of those cavities on the plinth does not respect any geometric order or symmetry. They appear for the most part on arch 1 (fig 1) and are missing on the portion of arch 2 and ring B that were brought to light¹⁶.

¹⁴ Villedieu 2021, 233-239.

¹⁵ Holes chiselled *ab antiquo* as they were covered by elements of Flavian demolition, Villedieu 2021, 236 and fig. 200.

¹⁶ The function of these cavities is unclear but, as they were intentionally excavated, requires further analysis. The proposal to consider them as locations for bronze spheres to support the *cenatio* and allow it to rotate will be discussed below.

A series of travertine modillions is located within the outer side of cylinder B, with a regular pitch of approximately 1.5 m, just below the summit plane (fig. 1), at an elevation of -0.85 m. Only two of them remain on the cylindrical wall A, one of which is located in correspondence with a similar modillion of the B¹⁷ ring, as shown in Fig. 1. Their function can be interpreted as supporting a wooden framework to allow the passage of maintenance personnel, as will be described later.

The intermediate floor is defined by two rings: the first between pillar C and B, 4 m wide, the second positioned between B and A, 3 m wide. A doorway within cylinder B located next to compartment D, below the adjacent arch, allows passage between them (fig. 2). The floor of this double ring zone is at an altitude of 37.73 m asl and it is not perfectly levelled, but it has differences in height of the order of 10-12 cm.

The remains of compartment D, after the demolition of the masonry between the arches 1 and 2 (fig. 1), are found between the top floor and the intermediate floor, thus for a height of approximately 6 m and a width of 3 - 4 m.

Among the remaining iron beam fragments in compartment D, the end part of A1 beam (Fig. 4a) is shown: it emerges horizontally from the vertical wall, numbered 2 just above the pavement of the lower floor (fig. 1). The small size of the pin inserted into the beam (3 mm) and also the end ferrule are worth noting. The U-shaped bracket, mentioned above, at its top also has a through-hole with a rectangular cross-section and sharp edges measuring approx. 12 x 7 mm (Figs. 4b, 4c). Such high-precision machining parts presuppose connections with similar mechanical components that are no longer present. Nevertheless, the different positions of these components do not allow them to be connected and their function is currently unknown. These components and the traces of the high-precision machining, make it clear that they were parts of a mechanically complex structure on whose function it is difficult to speculate.

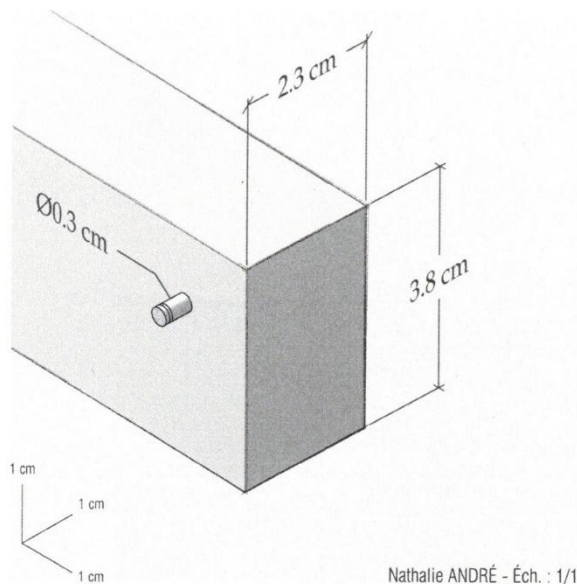

Figure 4a. Beam A1 (draw N. André, Villedieu 2021, 246, fig. 221).

Figure 4b. U-shaped bracket still embedded in masonry seen from the East (Photo A.).

¹⁷ The modillions could support a wooden framework for the operations related to the functioning of the *cenatio*. Villedieu 2021, 350-351.



Figure 4c. U-shaped bracket of fig.3b, enlarged, seen from the West (Photo A.).

2. Possible technical solutions for the cenatio machine: general characteristics

2.1 Hydraulic machine.

Following Suetonius description, the cenatio rotated constantly day and night¹⁸: nothing else than a hydraulic machine, *hydraleta*¹⁹, could generate the necessary mechanical power. The use of hydraulic power, developed since the Hellenistic period²⁰, had reached a maturity that, by the 1st century AD, had allowed it to be diffused widely, reaching even the rural sphere²¹. The machine type with a horizontal axis wheel was the most employed, as it was more efficient than the vertical one and had lower rotational speed²². The NE portion of the Palatine that housed the structures in question was fed by the branch of the *Aqua Claudia* expressly built in the Neronian age²³, which carried a high flow of water for the countless uses that Nero's eclectic mind had conceived for the transformations of the imperial palaces.

Large reservoirs have been identified in the central and southern parts of the Palatine Hill²⁴, but all the land between these and the pavilion of the *cenatio* was used for constructing other buildings, largely modifying it. New excavations could find elements of canalisation, but currently there is no trace of them. From the plan of the *cenatio* building, it can be logically assumed that the water supply channel was located in a direction parallel to the tangent to point D of the circumference of B ring (Fig. 1 and 5). The technical conditions suggest that this is the maximum possible approximation, in plan and elevation, between the axis of the wheel and the tothing of the platform to be moved. In the absence of information in this regard, it is noted that the altitude of the channel ending on the Palatine of the *Aqua Claudia* called *Arcus Caelimontani* is positioned 55 m asl²⁵, while the altitude of the platform is 43.73 m asl, making the altitude range for the possible channel of the hydraulic machine quite wide.

¹⁸ Suet. *Nero*, 31, 1.

¹⁹ Latin *hydraleta* (Vitr. X.5.2), from the Greek: Suetonius (*Geogr.*12.3.30).

²⁰ Lewis 2000, 33-61, Fleury 1994.

²¹ Wikander 2000, Spain 2008, Kessener 2010.

²² Wikander, 2000.

²³ Tomei 2021 373-390, Tucci 2006, Schmölder-Veit 2011, Gautier Santucci 2020.

²⁴ Tomei 2021.

²⁵ Tucci 2007, Schmölder-Veit 2011.

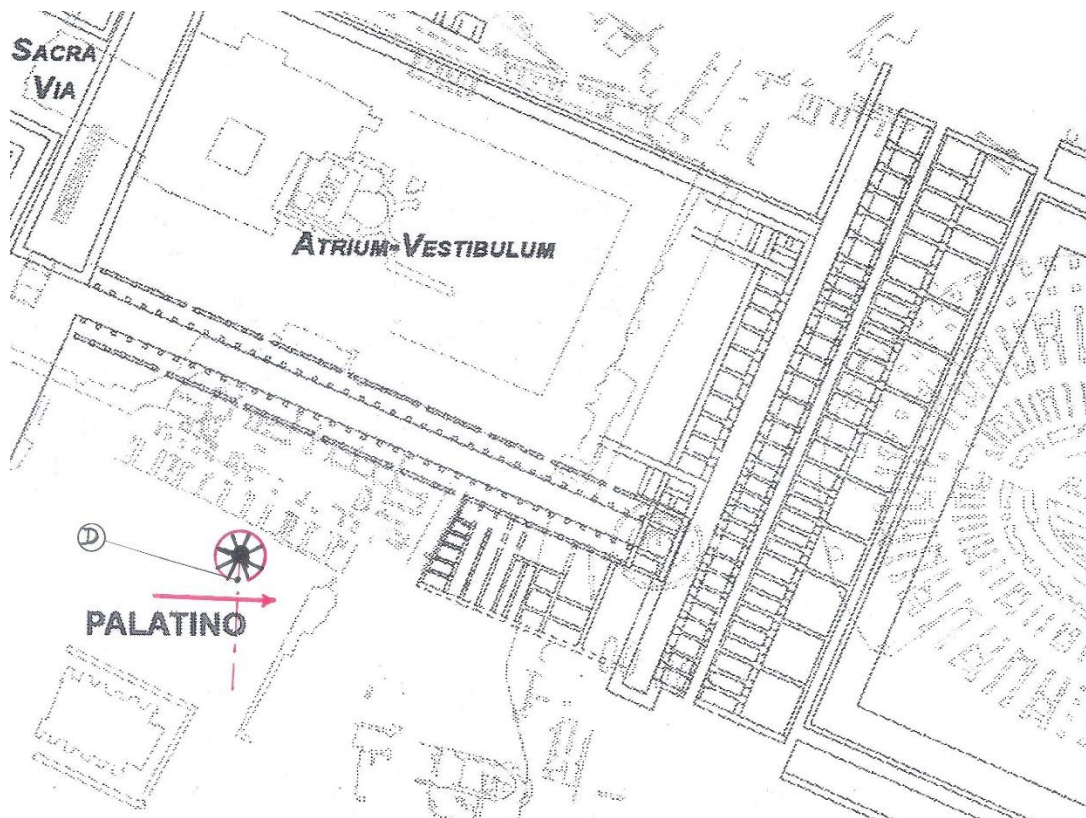

Figure 5. Layout of the channel feeding the hydraulic wheel on the plan of the Domus Aurea building blocks reconstruction. (Panella 2013, modified).

There is room for much speculation regarding the position of the channel and the size of the hydraulic wheel. Future excavations may find traces of this, but the floor level of the access structure to the cenatio would remain unknown, with no possibility of reconstruction. In the absence of these elements, which would make it possible to physically locate the missing structure, we proceed by identifying solutions for the functioning of the machine, based on the technologies and means available at the time of the construction.

2.2 Dimensions of the *cenatio*

On the basis of the surfaces identified by the basements of A, B, and C, and the compartment D position and dimensions, the following alternatives for the dimensions of the *cenatio* are examined:

- Diameter equal to that of the inner circumference of B, equal to 12 m (40 Roman feet – R.f.), resulting in a surface area of 113 m².
- Diameter the outer circumference of B, equal to 16 m (54 R.f.), in which case the surface area becomes approximately 200 m².
- Diameter greater than ring B, with the platform also occupying the space between rings B and A.

To our knowledge, all three hypotheses are possible, however, the second one is preferred. The motor gearbox and cenatio gearing must be easily accessible to personnel responsible for the operation of the machine. Maintenance personnel may work from the walkway between B and A as seen before²⁶.

²⁶ See note 16.

With the measurement of 200 square metres, the area of the cenatio becomes larger than that of the octagonal hall of the *Domus Aurea* on the Palatine Hill²⁷, a banquet hall that was the emperor's private residence. In this case the *cenatio* would have a sufficiently large space suitable for both official banquets²⁸ as well as for those limited to the circle of confidants (*familiares epulae* Suet. Nero xxii,3). The diameter of 12 m (size of the first hypothesis) would provide a limited space for such pavilion. The *cenatio* could also have had a diameter exceeding the crown B, with a cantilevered part in the space between A and B, supported by a reticular structure.

3 Hypothesis 1: *Cenatio* on wheels.

3.1 The structure

A technically simple solution for the operation of the *cenatio rotunda* could consist of a wooden platform resting on a set of wheels²⁹. It can be proposed a wooden base resting (fixed) on the upper platform in the form of the masonry at the B-C plane, on which wheels were fixed, each mounted on its trestle. We assume 1200 mm diameter wheels rimmed with 50 mm iron ring. These wheels would be similar to those of the chariots in use at that time (Fig. 6), which by then had reached a high degree of technical and constructive maturity³⁰.

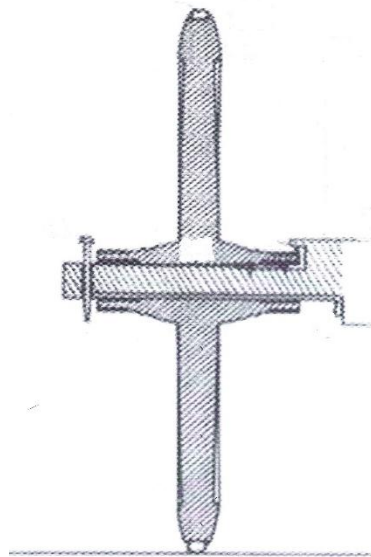

Figure 6. Rimmed wheel from a four-wheeled chariot (detail from Miniero 1987, fig. 17).

In order to arrange the load on the surface as to limit the stress on the structure, a support system consisting of wheels angularly distributed on three concentric rings is proposed.

²⁷ The diameter of the circle inscribed in the octagon (the double apothem) is 13.60 m: Fabbrini 1995, 58.

²⁸ Sojic, Winterling 2009, 294-301.

²⁹ Gabay 2021, 320-331, proposes the hypothesis of a rotating platform above bronze spheres (crank webs) inserted into the 26-30 cm diameter hemispherical cavities in the surface of the basement (see note 16). This solution seems unrealistic as there is no evidence of balls bearings rotating only on themselves within a hollow, also considering the difficulty of turning such components, as discussed in Gautier 2021, 333.

³⁰ Miniero 1987. 191-193.

Sixteen wheels would be positioned on the outer ring of B, eight on the top of the arches, and four on the central tower, for a total of 28 wheels (Fig. 7). The outer wheels rotate on 15 m diameter, the intermediate wheels on 8 m diameter, and the inner wheels on 3 m diameter, corresponding to the three above mentioned structures, respectively. In this way, the supports are placed at a distance of approximately 3 m and the load is sufficiently uniform. The centring of the rotating part is easily maintained by three or more wheels arranged tangentially to its circumference.

The tracks where the wheels turn could be covered with leather or textile, nailed to the wood, to cushion the noise of the motion. A rotating structure could then consist in a wooden platform, (6 cm tick), a 60 cm tick reticular structure, also made of wood, and the walking surface having the same thickness as that underneath. Using oak wood (specific mass of 800 kg/m³ for oak wood, 450 kg/m³ for linden tree wood), a total mass, including the furniture, of 20 t could be estimated for this structure. A load of 714 kg per wheel (20.000/28) is similar to the wagons of the time³¹.

The free spaces between the arches and the ring track between A and B would allow the workers to reach the floor between the two axles and carry out the necessary maintenance and repairs on the wheels and the equipment.

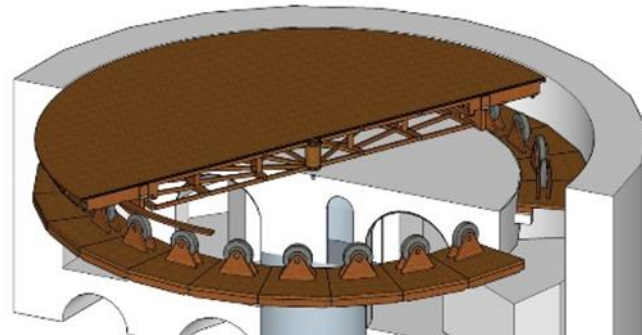

Figure 7. Example of wheels set only on outer ring (drawing A. Gaggero).

3.2 Gear train between the hydraulic wheel and *cenatio* platform

The gears utilised in the ancient world for the many *hydraletae* found were made of hard wood. Experience gained through centuries of use had refined their dimensions and shape. The classic form of movement transmission in larger ones had the hydraulic wheel in a vertical position with horizontal axis, on which a large toothed wheel (*tympanum maius dentatum*, Vitr. X,5,2) was mounted. It engaged with the lantern, (*tympanum dentatum*, Vitr. *ibid.*), held by a vertical axis that carried the grinding wheel at the other end. The lantern - gear transmission allowed the axial displacement of the gear without loss of connection. An example of a lantern was found at Zugmantel, a fort on the Germanic limes, north of Mainz³². Made of wood, it was equipped with six bars (Fig. 8).

³¹ Corradi 2003, 58-59.

³² Spain 2008, p. 3. About the fort of Zugmantel, now a UNESCO site whose Roman name is unknown, is about 20 km north of Mainz: www.Kastell Zugmantel.

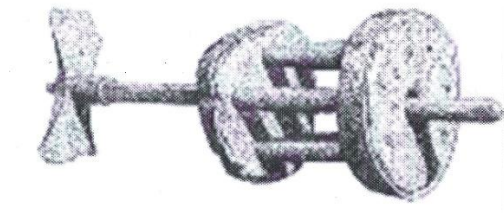

Figure 8. Roman lantern from Zugmantel (Spain 2008 p.3).

Another example which depicts a hydraulic marble sawing machine³³, can be seen in the relief on the sarcophagus of *M. Aurelius Ammianus* in Hierapolis of Phrygia³⁴ (fig. 9).



Figure 9. Sarcophagus of M. Aurelius Ammianus (Ritti 2017, 29, fig.3).

The lantern engages with a wheel with teeth positioned perpendicular to the plane of rotation. This is the solution adopted in all the numerous hydraulic mills with a vertical wheel from the Roman period that have been found (Fig. 10).

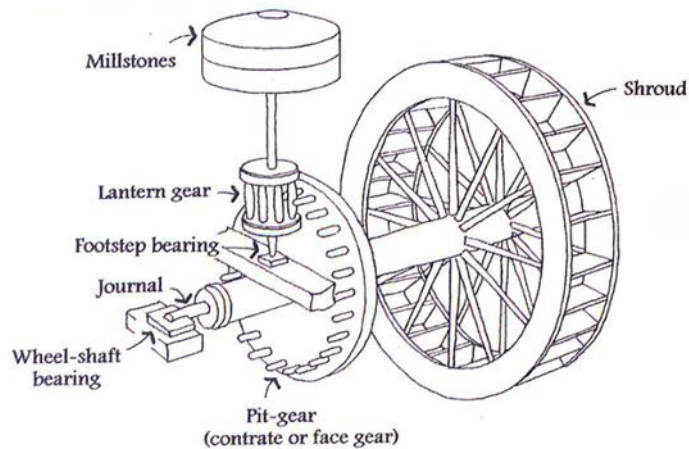

Figure 10. Classic diagram of water mill. (Spain 2008, fig. 84).

The gear ratio

One revolution per hour is assumed as the appropriate speed of rotation of the *cenatio*. The hydraulic wheel speed can vary depending on the wheel diameter and the water flow rate. By analogy with antique hydraulic mills, it is assumed a wheel of 4.5 m diameter, and a flow rate of 200 l/hour. The resulting rotation speed is 3.5 rpm (210 rph) and the useful power is 2 kW,

³³ Ritti, Grewe, Kessener, 2007.

³⁴ Above the elegant diagram of the machine, is the inscription: «*M. Aurel. Ammianos*, citizen of Hierapolis, skilful as Dedalus in wheel working, made with Dedalean craft». The sarcophagus is dated to the 3rd century AD., Ritti, 2017, 27 – 37.

which is far greater than required, but appropriate for the loads involved. The reduction, in the ratio 1/210, can be achieved with multiple gearwheel modes. No indication neither of their number nor their size are given from archaeological data.

The hypothesis minimises the number of wheel pairs to two, in order to reduce the number of rotating parts and the resulting energy losses through friction (sliding in contact). This could be achieved, for example, engaging a lantern of 0,44 m diameter as the first gear wheel to the *cenatio* platform (Fig 10). The first gear ratio becomes $16/0.44 = 36,36$. The lantern is installed on a long vertical axis carrying a horizontally oriented toothed wheel of 2,4 m diameter. This gear engages another lantern at right angles fixed on the horizontal axis of the water wheel, the lantern having the same diameter of the first one: 0.44 m. The second gear ratio then becomes $2.4/0.44 = 5.45$. The theoretical gear ratio thus becomes $36,36 \times 5.45 = 198,33$. With this gear ratio, the rotation speed of the platform is almost of one turn per hour.

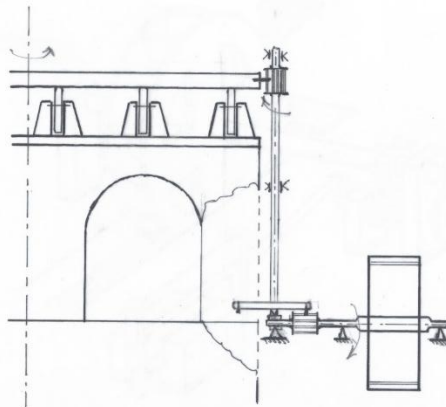

Figure 11. Drive diagram between hydraulic wheel and *cenatio* platform (drawing A.).

In this hypothesis, the two lanterns have an equal diameter of 0.44 m, each containing 6 bars (teeth) of 44 mm diameter each. It follows that the gear on the hydraulic wheel, given the gear ratio, contains 33 and the *cenatio* wheel 218. The practical gear ratio becomes $(218/6 \times 44/6) = 266,44$. These bars would be similar to the bronze pins used in the Pantheon's trusses, cylindrical pins 53 mm in diameter, and not far from their dimensions³⁵.

The involved forces

With the previous assumptions, the mass (M) of the rotating part bearing on the wheel system is 20000 Kg, which when distributed over 28 wheels becomes on average 714 kg/wheel, feasible load for oak wood³⁶. Since the ratio between the pulling effort and the weight force is not determined for this case of rolling on wood, therefore it is evaluated by analogy with the dynamics of a chariot drawn by a pair of oxen³⁷. The ratio between the load effort and the weight force is estimated, based on the calculations exemplified³⁸, to be $\delta = 0,2$ (fig. 12). Considering that the load effort $L=Mg$, where M is the mass and g is the gravity acceleration, for the specific case $L=20 \cdot 10^3 \times 9,8 = 196,2 \times 10^3 \text{N}$, which can be approximated to $200 \times 10^3 \text{N}$.

³⁵ Heinzelmann 2016, 71, fig. 15-17.

³⁶ Developing the approach suggested by Kozan et al. 2021.

³⁷ The typical transport chariot like the *carrus* of Ariadne's villa already used as a reference for the wheels, Miniero 1987.

³⁸ The resistance coefficient in case of a chariot moving on a smooth wooden surface with hubs rotating on oil-impregnated wooden supports can be assumed to be $\delta = 0.2$. Thank to Vincenzo Vullo for support and verification in calculations.

The force on the tooth primitive integral to the platform ($F = \delta \times L$) becomes:

$$F = 0,2 \times 200 \times 10^3 \text{N} = 40 \times 10^3 \text{N (or 40 kN)}$$

This high intensity force would require suitable metal structures for transmission. Conditions impossible with the techniques and materials of the time.

Even changing the number of gear pairs, with the masses and dimensions considered above does not change the force to be transmitted to the platform. The system can only work if the force is divided between a large number of teeth, but in that case it would be necessary to provide for subsidiary form of energy.



Figure 12. Weight force F acting on the four wheels and force T required to pull the wagon (Mosaic from Villa del Casale, Piazza Armerina Sicily).

The drive torque to be applied to the tooth of the platform is $T = Fr$, where r is the radius of the first platform primitive: $r = 8 \text{ m}$, which becomes:

$$T = 8 \times 40 \text{kN} = 320 \text{kNm.}$$

At the speed of one turn per hour ($\omega = 2\pi/3,600$) the requested power becomes:

$$N = T\omega = T2\pi n/60 = 320 \times 10^3 \times 2\pi/3600 = 558,5 \text{W.}$$

Assuming the efficiency of each of the two gear pairs as 0,9, the power of the *hydraleta* becomes:

$$N_H = N \times 0,9^2 = 689,5 \text{W}$$

To move the machinery would thus would be sufficient an *hydraleta* of one kW, but as seen above, distributed, not concentrated on a single gear.

4. Hypothesis 2: *Cenatio* as an island

4.1 The structure

A totally different technical solution that eliminates mechanical friction can be achieved by transforming the rotating platform into a floating body positioned within a suitable tank filled with water. The *cenatio* would thus be transformed into an island.

This solution was possible to be engineered for the technicians of the time, the *fabri navales*, who had built a wooden *natatio* in the *Campus Martius* in less than a year³⁹ to create a watertight basin on the upper floor of the building. Placing a pontoon inside it, they obtained the vast surface area to house the *natatio* furniture: containing decorations worthy the emperor's splendour. A luxurious lunch on the lake of Augustus' *naumachia* in Rome's Trastevere, with the participation of Nero, is recorded by Tacitus⁴⁰. Ceremonies and spectacles on the water were already in use by Nero's predecessors and the construction of the relevant structures had a long tradition.

The floating *cenatio* within a watertight carpentry tank placed on the basement can be realised in very different ways, which can be schematised by two highly diverging structures. One consisting of a simple raft, aiming at maximum simplicity, the other realised as a real vessel. Both can be installed within a specific tank made of carpentry and kept in rotation with the thrust of the hydraulic wheel similar to the one already proposed for *cenatio* on wheels (Fig.11). The main characteristics are outlined below.

To schematise the first one with concrete dimensions, a raft with an external diameter of 16 m is considered, made in two parts where the upper one is the proper *cenatio*, the structure capable of hosting imperial ceremonies. This part was to be placed on the same level with the access and reception pavilions for imperial court and guests. The lower part, rigidly connected to the first, is the real floating body, as shown in the diagram in Fig. 13.

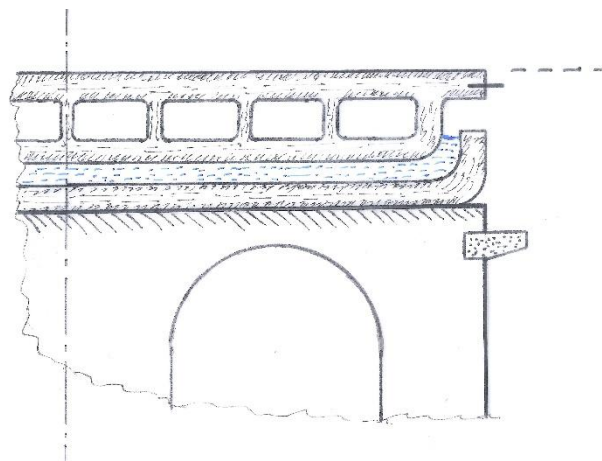

Figure 13. Schematic diagram of a tank containing a raft resting on the basement (drawing A.).

The raft has a truncated cone shape corresponding to that of the tank, the inside boxed so as to contain any additional ballast. It should have been completely watertight due to the difficulty of pumping the water out during operation, so it is conceived caulked and sealed externally with lead slabs. For a structure of this size with a diameter of 15 m, a mass of 50t can be estimated: 35t for the hull part (keel, planking, beams, props), 15t for the concrete ballast. Adding to this weight 4t for 2 mm thick lead soldered slabs and 16t for the upper

³⁹Suet. *Nero*, 12.1; Tac. *ann.* xiii, 31; Plin *n.h.* xix.6.24. Nero had attended Claudius' *naumachia* on Fucino Lake and organised two of them, in 57 and 64, during his empire, Berlan Bejard 2006.

⁴⁰*Igitur in stagno Agrippae fabricatus est ratem, cui superpositum convivium, navium aliarum tractu moveretur, naves auro et ebore distinctae*, Tac. *ann.* XV, 37. He had a raft constructed on Agrippa's lake, put the guests on board and set it in motion by other vessels towing it. These vessels glittered with gold and ivory. <http://data.perseus.org/citations/urn:cts:latinLit:phi1351.phi005.perseus-eng1:15.37>.

platform with furniture and guests, a total of 70t is reached. The submerged surface of the raft is defined by the circumference of 15 m in diameter, so the buoyancy causes a rise H (mass in kg transformed into m³ of water) equal to:

$$H = 70,000/\pi \times 7.5^2 = 0.39 \text{ m}$$

The pool structure with raft has a total height between the base and the final floor of the cenatio of 1.2 m, floor level which should be aligned with that of the still unknown access pavilions.

Given its dimensions, the raft has a high moment of inertia ($I = Mr^2/2$), equal to

$$I = 70 \times 10^3 \times 7.5^2/2 = 1969 \times 10^3 \text{ Kgm}^2$$

Which can be approximated to $2 \times 10^6 \text{ kgm}^2$.

Rotating such a raft at the speed of one revolution per hour requires a power of:

$$W = 1/2I\omega^2; \text{ where the rotation speed } \omega = 2\pi/3,600 = 3.04 \times 10^{-6} \text{ rad/s,}$$

$$\text{with the previous data } W = 2 \times 1/2 \times 10^6 \times 3.04 \times 10^{-6} = 3 \text{ W.}$$

A limited power is required to start the rotation of this structure, but the force F exchanged on the contact point, which is the single pin of the raft is:

$$F = W/v, \text{ where } v \text{ is the peripheral speed of the pin } (v = 2 \pi \times 8 \times 1/3,600 = 13.9 \times 10^{-3})$$

$$F = 3 / 13.9 \times 10^{-3} = 215 \text{ N.}$$

This value could represent an excessive load for a single pin embedded in the wooden structure of the platform. During start-up, however, the load can be spread over several pins and supported manually by specific personnel moving on the annular corridor positioned under the basement.

Obviously, these are broad calculations that do not take into account the friction caused by contact with the lateral elements for centring of the rotating structure.

Once the raft reaches a speed of one revolution per hour, it is only braked by limited hydrodynamic losses. The hydraulic machine described above is able to transmit the necessary thrust and guarantee rotation constancy. The motion can be compared to a small vessel sailing on calm waters: a few oar strokes are enough to keep the speed constant.

A more challenging solution for the dinner-island could be inspired by Caligula's two ritual ships on Lake Nemi, both conceived as ships - palaces in the Hellenistic tradition to exalt royalty⁴¹. Significant masonry buildings were constructed on them: on Ship One a 'palace' that Nero restored by raising it on *suspensurae*, (Fig. 14) and on Ship Two a temple⁴². Both buildings had marble floors (*opus sectile*), columns and rich decorations⁴³.

⁴¹ The two imposing ships built by *Gaius Caesar Imperator*, known as Caligula (37 – 41 AD) sank in the Nemi lake, were recovered in the years 1929 - 1932: Ucelli 1950. The two ships have similar dimensions and construction techniques, but different functions: Ship One carried a palatial complex, the better-preserved Ship Two a temple complex. The waterline dimensions of ship Two are: length 64 m, width 23.2, displacement 1684t, supporting buildings of different sizes and functions as partially reconstructed on the basis of the masonry foundations and marble architectural elements found. Ucelli 1950, Bonino 2003.

⁴² Bonino 2013, 120-121. I thank Marco Bonino for suggestions and clarifications.

⁴³ Recovered marble and bronze are in the National Roman Museum, Palazzo Massimo, Rome.

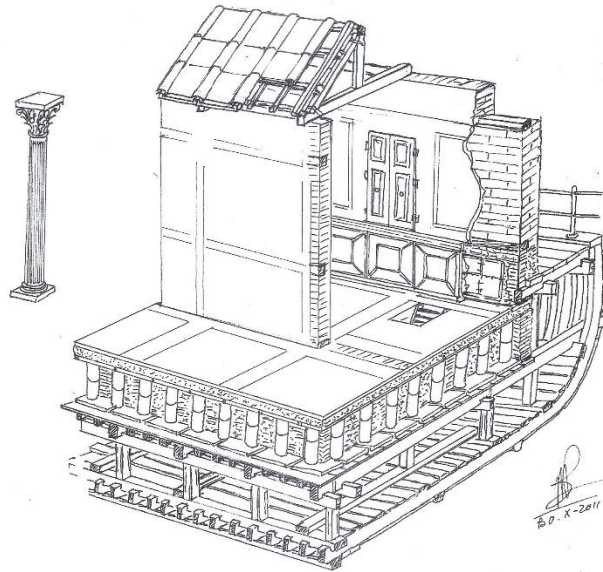

Figure 14. Nemi ship One section (Marco Bonino unpublished drawing).

In case of the *cenatio*, a circular, flat-bottomed watertight pool with a diameter of about 16 m would have been built on the structure, caulked and lined with lead slabs, in order to place the ship-shaped pontoon-island inside.

More specifically, a ship with a load-bearing shell with a circular structure should have the fundamental variant, compared to classical naval architecture, of mounting a keel with beams arranged in a radial pattern. On top of this there would have been space for a concrete casting and the laying of an *opus sectile* marble floor. If this had been the solution chosen for Nero's *cenatio*, the vessel would have been completed with lead slabs cladding, suitable also to increase stability, as the ships of Nemi well represent⁴⁴. Its construction would have taken place above the basin and its installation would have been carried out by dismantling the scaffolding necessary for its construction and filling the lower basin with water until the pontoon was afloat.

A structure formed by a slab with a total thickness of 17 - 20 cm can weigh 80 - 100 tonnes, plus the 60t of the pontoon would give a total weight of 120-150t⁴⁵. The island would float, immersed in the basin, to a depth easily calculated using Archimedes' principle: estimating a total weight, pontoon and furniture of 160t, and a waterline surface⁴⁶ of 170 m², this would result in an immersion of 0.94 m. Appropriate pipes for water intake and for the 'overflow' would complete the tank's fittings, while three or more wheels fixed on the external structure could act as fenderings to keep the pontoon-*cenatio*'s rotation centred.

⁴⁴ Bonino 2003, pp. 89 – 109.

⁴⁵ In analogy to the findings on the floor of the ship Two of Nemi (Ucelli 1950, 161), we consider a structure formed of terracotta tubules of appropriate height (40 cm) supporting bipedals on which a cast of earthenware 10-15 cm thick and then another of mortar on which the *opus sectile* are laid. This results in a thickness of 17 - 20 cm, making the total thickness of the platform of the order of 1.2-1.6 m. The resulting load is estimated to be 200 - 250 kg/m².

⁴⁶ According to Archimedes' principle, the displacement, 0.94m comes from the ratio 160 m³/170 m².

The mighty masonry of the structure that emerged from the excavations could have easily withstood the loads of the pool, platform and furnishings⁴⁷. The planners could have chosen this option by embarking on the realisation of an unique structure full of uncertainties from an engineering point of view, but fitting well within the tradition of Alexandrian science, widely accepted in Rome⁴⁸. The experimental nature of the construction would have allowed the possibility of easily and quickly varying the shapes and sizes of the various components for fine-tuning as the work progressed. In fact, a wooden tank and a pontoon-island could be modified in size, height and whatever else was appropriate during construction to provide the most suitable solutions for the final objective. The alternative of constructing a masonry tank would certainly have been possible, but would have placed constraints on the laying and gripping of masonry and hydraulic plaster not suited to the flexibility and time required for this undertaking.

In this hypothesis, the space for maintenance operations, where the wheels for centring the floating-*cenatio* are positioned, as well as the water supply to the tank, with a check overflow placed in appropriate niches (three as minimum) located above the tank and the float, would be accessible from the annular corridor made above the modillions between A and B.

Starting the rotation of a 160t displacement pontoon can be equated to moving a vessel with a load of 3,000 amphorae, similar to that used in the Ostia-Rome route (*caudicaria*) pulled by pairs of oxen. Also in this case, as in the case of the *cenatio*-raft, operation would have required two phases: the first to start the rotation of this structure of high inertia by means of the thrust of specific personnel. Once the *cenatio* reached steady speed, it was only braked by hydrodynamic losses, replaced by the thrust transmitted by the hydraulic machine.

It can be assumed that the connection between the hydraulic wheels and the tothing of the *cenatio* platform was similar to that mentioned above for the *cenatio* on wheels (Fig. 11). When the platform was running at its steady speed (one revolution per hour), the hydraulic wheel could easily provide the contribution of energy overcoming the modest hydrodynamic resistance to rotation.

Based on the thickness of the basin, pontoon and floor, it can be assumed that the floor level of the Neronian Palatine pavilion, and thus of the *cenatio*, was 2 - 2.5 m above the top floor of the *cenatio*⁴⁹, thus 45-46 m asl, or even 47.5 m asl if in continuity with the upper floor of the Flavian palace⁵⁰.

5 The *cenatio* machine and Hellenistic engineering

Structures such as those proposed here are not described in literature and artifacts. However, it has been shown, based on the evidence from various objects of that time, that the machine

⁴⁷ Estimating a weight of 150t for the pool and the floating platform, the total weight could become 300-350t and would have been borne by the surface area of approximately 102.5 m² between core and crown. The resulting specific load would have been approximately 0.3 kg/cm², which is lower than the permissible load used in Roman architecture (Giuliani 2006, 237-238).

⁴⁸ Machines for performances in theatres, circuses and naumachiae were large enough to be seen by spectators: the great naumachia of Claudius for the celebrations of the completion of the draining of Lake Fucino was an example (Suet, *Claudius* 21).

⁴⁹ Considering equal to 0.6 m the consistency of the bottom of the tank and 2 m between the thickness of the island and the space till underneath water.

⁵⁰ If the floor of the Domitian palace retained the height of the Neronian pavilion instead of that of the *cenatio*, the latter would be at a level of 47.48 m a.s.l., as evidenced by the remains under the Palatine Antiquarium (Cassatella 1995, 50).

mentioned by Suetonius was feasible to be constructed with the knowledge of the technology of the time, within the Neronian structures.

Water mill gears had become objects of widespread use from the 1st century B.C. onwards, so a vast experience of shape and size had been accumulated, as witnessed by the numerous examples that archaeology continually yields.

The knowledge of gears was applied in the Greek, Hellenistic and Roman worlds in a dual scale⁵¹: to move heavy masses, on construction sites for large buildings, by means of the *baroulkos*, as described by Heron⁵², or with very small dimensions, as in the odometer, the instrument that measured the distance travelled by a chariot. The odometer achieved a reduction ratio of 1/400 with only one set of gears (Vitruvius X. 8.9). The chariot wheel had a diameter of 4 Roman feet, travelling in one revolution 4π R.f. which in 400 revolutions becomes $400 \times 12.5 = 5,000$ R.f. i.e. one Roman mile. The odometer was made with a single-toothed wheel, installed on the axle of a chariot wheel. The single-toothed wheel geared with another wheel having 400 teeth, so that with each revolution of the former the latter moved one position ahead. When this completed 400 clicks, it dropped a ball through a hole into a lower sleeve. At the end of the day, the number of balls collected indicated the number of miles travelled (fig. 15).

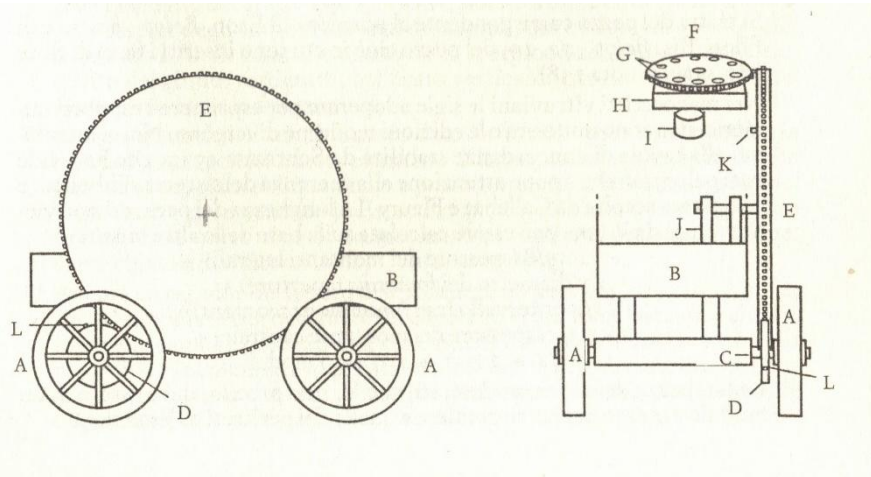

Figure 15. Odometer scheme, lateral and front view. A, chariot wheel; B, coffer; C, rigid axle; D, single toothed wheel; E, toothed wheel; I, lower sleeve. (Vitruvio 1997, 1391, fig. 3).

The development of complex gear systems has enabled the realisation of precision instruments such as the Antikythera mechanism⁵³. Composed of gears, but of a completely different kind, the Antikythera mechanism is an astronomical instrument from the 3-2nd century BC that followed the movement of the Sun, Moon, and other stars. It was equipped with numerous toothed wheels that, in addition to direct gearing, had an epicyclic operation, so as to follow the movements of astral bodies with different periods⁵⁴. Since its discovery in 1900, studies of the complex Antikythera mechanism have been underway using state-of-the-art

⁵¹ Vullo 2020, 31 – 56.

⁵² Drachmann 1963, 22–32., Ferriello et al. 2016.

⁵³ Astronomical instrument from the end of the 2nd century BC, testifying a level of technology not otherwise documented. It demonstrates the use of complex gear systems such as the differential. Extensive analyses using the technological advances of the time (X ray Tomography ...) have been ongoing since the 1970s, (UCL Antikythera Research Team), for a recent summary: Jones 2017 and in particular Michael T. Wright in this Conference.

⁵⁴ Tassios 2012.

technology. Its structure goes beyond that of the *cenatio*, but it is recalled here to remind us of the degree of complexity reached by ancient science and the lack of concrete evidence for much of the work.

The qualification of the architects Severus and Celere is specified as *magistri et machinatores*, (Tacitus *ann.*15,42,1), thus not mere architects, but emphasising their specialised qualification and the term *machinator* gives the sense of complex equipment⁵⁵.

6 Conclusions

The structure recently found in the Palatine Hill excavations, has the typical features of Neronian architecture. It represents the lower part of a pavilion of the Palatine *Domus Aurea* that was previously completely unknown.

Suetonius' testimony allows us to develop with factual reasoning the hypothesis that we are dealing with the central part of Nero's *cenatio rotunda*, a structure that rotated continuously.

The archaeological rediscovered evidence, though severed shortly after Nero's death, includes structures capable of supporting a rotating circular platform. The structure clearly shows a partly demolished area where fragments of metal beams torn from the masonry and precision mechanical components appear.

In this area of the Palatine there was abundance of water, brought by Nero with a special branch of the *Aqua Claudia*, so there is no obstacle to assume a water wheel as a motor for the *cenatio*.

The technically possible solutions to support the aforementioned platform, allowing it to rotate, fall into two categories: the first uses a series of wheels fixed on the base, while the second considers the *cenatio* mounted on a floating pontoon above a basin filled with water. Both platforms are equipped with gears that are connected to the hydraulic wheel by a gear train.

The first hypothesis is developed with twenty-eight wheels anchored to a platform fixed to the base. The solution is mechanically simple, but the significant mass and the resistance to be maintained in rotation makes it highly problematic to operate with only the thrust of the hydraulic wheel. The materials available at that time would not have been able to support the necessary load (20 kN) that has been assumed.

The second hypothesis considers the *cenatio* placed above a floating raft within a carpentry tank resting on the basement. Rotation would have required overcoming the moderate hydrodynamic resistance opposed by the hull. Laws of Kinematics and Dynamics suggest this as the solution to continuous motion day and night.

Bibliography

- Batino, S., Corradi L., Corradi S., Marchetti M., Rasimelli S., Schippa G., Tortorato M., 2003, *Il traffico sull'antica via Flaminia. Viabilità e mezzi di trasporto romani*, Arrone.
- Berlan-Bejard, A., 2006, *Les spectacles aquatiques romains*, Collection École Française de Rome (CEFR), 360, Roma.
- Bonino, M., 2003, *Un sogno ellenistico: le navi di Nemi*, Pisa.
- Bonino, M., 2013, *Alcune note sull'architettura e sulla tecnica costruttiva delle navi di Nemi e dei loro edifici. Caligola. La trasgressione del potere*, Catalogo della mostra, Nemi, 5, 6-5,11 2013, Roma, 115-124.

⁵⁵ Coarelli 2021, 419-420.

- Bruno, D., *Region X*, Carandini, Carafa (ed.), 2017, *Atlas of Ancient Rome, biography and portraits of the city*, Princeton, 215-280.
- Cassatella, A., 1995, *Domus Aurea*, s.v., *Lexicon Topographicum Urbis Romae II (LTUR II)*, Roma.
- Coarelli, F., 2012, *Palatinum. Il Palatino dalle origini all'Impero Romano*, Roma.
- Coarelli, F., 2021, *La praecipua cenationum rotunda*, *Villedieu 2021*, 419 – 432.
- Corradi, L., Corradi S., 2003, *Le pressioni di contatto fra la ruota e l'impalcato*, *Batino et al*, 85-105.
- Drachmann, A.G., 1963, *The mechanical technology of Greek and Roman antiquity. A study of literary sources*, Copenhagen.
- Fabbrini, L., 1995, *Domus Aurea. Il palazzo sull'Esquilino*, *LTUR II*, 56-63.
- Fedeli, M., 2021, *L'opera testacea della costruzione neroniana*, *Villedieu 2021*, 253 – 282.
- Ferriello, G., Gatto, M., Gatto, R., (ed.), 2016, *The Baroukos and the Mechanics of Heron*, Firenze, Biblioteca di Nuncius, Studi e Testi LXXVI.
- Fleury, Ph., 1994, *La mécanique de Vitruve in Le projet de Vitruve. Objet, destinataires et réception du de architectura*. Actes du colloque international Rome, 26-27 mars 1993, *CEFR 192*, Roma, 187 -212.
- Gabay, M., Gabay, D., 2021, *Élaboration d'hypothèses sur le mécanisme hydraulique employé pour assurer la rotation de la salle à manger tournante du palais de Néron à Rome*, *Villedieu 2021*, 320 – 331.
- Gautier di Confiengo, E., Santucci E., 2020, *The distribution of Aqua Claudia and Anio Novus in Rome*, *Wiplinger (ed.), De Aqueductu Urbis Romae, Sextus Iulius Frontinus and the Waters of Rome*, International Conference Rome 2018, *Babesch Sup.*, 40, 85-100.
- Gautier di Confiengo, E., 2021, *La macchina della cenatio rotunda neroniana. Ipotesi di ricostruzione*, *Villedieu 2021*, 331-340.
- Gros, P., 2021, *Vice Mundi. L'astronomie au service du pouvoir*, *Villedieu 2021*, 405 – 417.
- Häuber, C., 2024, *Preview FORTVNA PAPERS 3, Domitian, Palatine, Nollekens Relief*, in: https://fortvna-research.org/Digitale_Topographie_der_Stadt_Rom/
- Heinzelmann D., Heinzelmann M., 2016, *The bronze Truss of the portico of the Pantheon in Rome*, *Camporeale, Dessales, Pizzo (ed.), Arqueología de la Construcción. V. Man-made Materials, engineering and infrastructure*, Madrid-Mérida, 59-73.
- Jolivet, V., 2023a, *Vigna Barberini 3. La cenatio rotunda*, *Review*, *Ant. Classique 92*, 309-315.
- Jolivet V., 2023b, *Un Phare d'Alexandrie à Rome? Fragaki, Nenna, Versluys (ed.), Alexandria the Cosmopolis, A global perspective. Études Alexandrines 56-2022*, 313-346.
- Jones, A., 2017, *A portable cosmos. Revealing the Antikythera mechanism*, *Scientific Wonder of the Ancient World*, Oxford.
- Kessener, P. 2010, *Stone Sawing Machines of Roman and Early Byzantine Times, the Anatolian Mediterranean*, *Adalya XIII*, 283-303.
- Kozkan, G., Z., Karwat, Z., Kozakiewicz, P., 2021, *An attempt to unify the Brinell, Janka, and Monnin hardness of wood on the basis of Meyer law*. In *Journal of Wood Science*, Elsevier 67:7 2021. <http://doi.org/10.1186/s10086-020-01938-4>.
- Lewis, J.T., 2000, *The Hellenistic Period*, *Wikander, (ed.), Handbook of Ancient Water Technology*, Leiden, 631-648.
- Miniero, P., 1987, *Studio di un carro romano dalla villa c.d. di Arianna a Stabia*, *MEFR 1987*, 171-209.
- Moormann, E.M., 2020, *Nerone, Roma e la Domus Aurea*, Roma.
- Panella, C., 2013, *La Domus Aurea*, Panella (ed), *Scavare nel centro di Roma*.

- Ritti, T., Grewe, K., Kessener, H.P.M., 2007, *A relief of a water-powered stone sawmill at Hierapolis*, J.R.A., 20, 139-163.
- Ritti, T., 2017, *Storia e istituzioni di Ierapolis*, Ierapolis di Frigia IX, Istanbul.
- Schmölder-Veit, A., 2021, *Aqueducts for the Urbis Clarissimus Locus: The Palatine's water supply from Republican to Imperial Times*, (The Waters of Rome 7 - <http://www3.iath.virginia.edu/waters/Journal7SchmolderVeit.pdf>)
- Sojic, N., A. Winterling, A., 2009, *I banchetti nel palazzo imperiale in epoca flavia attraverso le testimonianze archeologiche e letterarie: tentativo di una interpretazione interdisciplinare*, Coarelli (ed.), *Divus Vespasianus, il bimillenario dei Flavi*, Roma, 294-331.
- Spain, R., 2008, *The power and Performance of Roman Water Mills. Hydro -mechanical Analysis of Vertical wheeled Water Mills*, BAR 1786, Oxford.
- Tassios T., 2021, *Prerequisites for the Antikythera Mechanism to be produced in the 2nd century BC*, Kaltsas, Vlachogianni, Bouyia, (ed.), *The Antikythera shipwreck, the ship, the treasures, the mechanism*, Athens, 249 – 255.
- Tomei, M.A., 2021, *Palatino. Nota sull'approvvigionamento idrico del Palazzo Imperiale da Augusto a Nerone*, Villedieu 2021, 373-389.
- Tucci, P.L., 2006, *Ideology and technology in Rome's water supply: castella, the toponym aqueductum, and supply to the Palatine and Caelian hills*, JRS 19, 2006, 95-120.
- Ucelli, G., 1940, *Le navi di Nemi*, Roma.
- Villedieu F., (ed.) 2007, *La Vigna Barberini II. Domus palais impérial et temples. Stratigraphie du secteur nord -est du Palatin*, Rome.
- Villedieu, F., 2010, *La Cenatio rotunda de la Maison Dorée de Néron*, CRAI, 1089 – 1114.
- Villedieu, F., 2016, *La Cenatio rotunda de Néron : état des recherches*, CRAI 107 – 126.
- Villedieu, F., (ed.), 2021, *Vigna Barberini III*, Roma Antica 9, Roma.
- Villedieu, F., André, N., 2021, *III, L'édifice Néronien: analyse des vestiges*, Villedieu, 2021,
- Vitruvio, 1997, *De Architectura*, Gros P., (ed.) Roma.
- Voisin, J.L., 1987, *Ex oriente sole (Suetone, Ner. 6). D'Alexandrie à la Domus Aurea*, L'Urbs: espace urbain et histoire (Ier siècle av J.C. – IIIe siècle ap. J.C.). Actes Colloquie International de Rome (8-12 mai 1985) Rome, CEFR 98, 509 – 543.
- Vullo, V., *Gears III: A concise history*, Springer Series in Solid and Structural Mechanics 12, Berlin 2020.



ΑΙΓΙΔΑ

ΕΛΛΗΝΙΚΗ ΔΗΜΟΚΡΑΤΙΑ
Υπουργείο Πολιτισμού

ΧΟΡΗΓΟΙ



ΤΕΧΝΙΚΟ
ΕΠΙΧΕΙΡΗΤΗΡΙΟ
ΕΛΛΑΔΑΣ



ΟΜΙΛΟΣ ΤΕΕ ΤΕΡΝΑ

ΥΠΟΣΤΗΡΙΞΗ



ΜΕΓΑΡΟ
ΜΟΥΣΙΚΗΣ
ΑΘΗΝΩΝ